



COMPANY WITH QUALITY MANAGEMENT  
SYSTEM CERTIFIED BY DNV  
= ISO 9001:2008 =

**BANCO PROVA FRENI UNIVERSALE**   
**PREDISPOSTO PER MCTC-NET2**

**UNIVERSAL BRAKE TESTER PRESET FOR**   
**2-3-4 WHEELERS**

**RAV**

**RT122**

**RT094**

Banco prova freni a rulli omologato per veicoli di massa massima fino a 3.500 Kg (auto, furgoni, camper) e motoveicoli 2-3-4 ruote (moto, tricicli, quadricicli, quad) e potenza da 4,70 Kw per soddisfare anche la clientela più esigente.

Le grandezze caratteristiche misurabili sono:

- Resistenza a libero rotolamento sulla singola ruota
- Ovalizzazione dei freni sulla singola ruota e differenza in percentuale
- Forza frenante massima sulla singola ruota, sull'asse e totale
- Squilibrio alla forza frenante massima in percentuale o squilibrio massimo in percentuale
- Efficienza totale dell'impianto frenante in percentuale
- Efficienza del freno a mano in percentuale
- Ripartizione di frenata fra assale anteriore e posteriore
- Peso dell'asse (nella configurazione completa di sistema di pesatura-P)
- Forza su pedale (solo con SRT047M).

Roller brake tester approved for 3.500 kg maximum load vehicles (cars, commercial vehicles, caravans) and 2-3-4 wheel motorvehicles (motorcycle, lightweight 3 and 4-wheeled vehicles, quad) with a motor power of 4,70 Kw to satisfy the most demanding customers.

These units are suitable for testing:

- Single wheel drag
- Brake ovality (out-of-roundness) on single wheels and percentage difference
- Maximum braking force on single wheel, on axle and total
- Maximum percentage unbalance of braking force
- Total percentage efficiency of braking system
- Percentage efficiency of handbrake
- Braking capacity split between front and rear axle
- Axle weight (P version only)
- Pedal pressure device (only with SRT047M)



**RT009**  
**(19" TFT monitor)**



SINCE 1958

DATI TECNICI	TECHNICAL DATA	RT122P4 - RT122P4F
Peso max di prova per asse (daN)	Max. test weight per axis (daN)	2500
Peso max al passaggio per asse (daN)	Max. transit weight per axis (daN)	4000
Forza frenante massima (N)	Max. braking force (N)	6000
Precisione celle di carico (%)	Load cells accuracy (%)	± 0,1
Velocità periferica rulli (Km/h)	Test speed (Km/h)	5,2
Motori (Kw)	Motors (Kw)	2x4,75
Diametro dei rulli (mm)	Roller diameter (mm)	205
Rivestimento rulli	Roller coating	Sintetico con cristalli di silicio Synthetic covering with silicium crystals
Coefficiente di aderenza	Coefficient of friction	> 0,7 anche bagnato dry and wet
Alimentazione	Power supply	400 V 50Hz 3 Ph

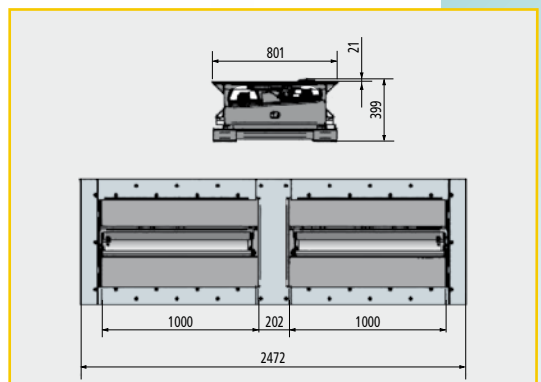



Eccellenza prodotto Made in Italy  
Top product - Made in Italy



### Componenti a richiesta Units on demand



SRT047M



SRT048

Tutti i banchi prova freni possono essere dotati di:  
All the brake testers can be equipped with:

Models		
<b>F</b>	Motori autofrenanti	Self-braking motors
<b>P</b>	Sistema di pesatura integrato	Integrated weighing system
<b>4</b>	Sistema di pesatura integrato a 4 celle	Integrated weighing system with 4 sensors



I set di coperture consentono di adattare rapidamente il prova freni da auto a moto.

The Set of drive-through covers allows to quickly adapt the brake tester from cars to motorcycles.

## BANCO PROVA VELOCITÀ SPEEDOMETER

Strumento flessibile per risolvere i problemi di chi ha poco spazio e di chi vuole offrire un servizio completo alla propria clientela. Grazie al freno a correnti parassite, il prova velocità offre la massima precisione di misura garantendo la massima affidabilità nel tempo.

Flexible equipment offering a complete service even to those customers with small-sized workshops. Thanks to the parasitic current brake, the speed tester can offer the maximum test accuracy with the maximum reliability.



DATI TECNICI	TECHNICAL DATA	RT094
Portata max al transito	Maximum capacity at transit	10.000 per singola ruota / for single wheel
Potenza Max dissipata dal dispositivo di frenatura	Max power dissipated by braking device	9 kW
Velocità max dei rulli	Top roller speed	80 Km/h
Alimentazione freno a correnti parassite	Parasitic current brake supply	72 V
Diametro rulli	Roller diameter	190 mm
Lunghezza rulli	Roller length	250 mm
Interasse rulli	Roller centre distance	900 mm
Lunghezza utile rulli	Roller working length	900 mm + 900 mm
Precisione cella di carico	Load cell precision	± 0,1% fondo scala / end of scale
Precisione catena di misura	Measurement chain precision	± 0,5% fondo scala / end of scale

### Componenti a richiesta / Units on demand



SRT047U



SRT047LMA

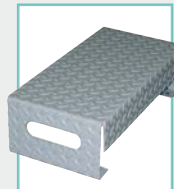

SRT101

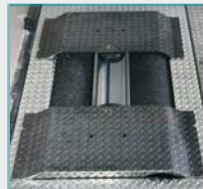

SRT102



SRT079M



SRT105

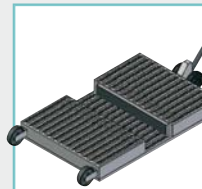

SRT106



Ravaglioli S.p.A.  
via 1° maggio 3  
Fraz. Pontecchio M.  
40037 Sasso Marconi (Bo) - Italia  
Tel. +39 - 051 - 6781511  
Fax +39 - 051 - 846349  
rav@ravaglioli.com  
www.ravaglioli.com

#### RAV France

6, Rue Longue Raie  
ZAC de la Tremblaie  
91220 Le Plessis Pâté  
Tel. 01.60.86.88.16  
Fax 01.60.86.82.04  
rav@ravfrance.fr

#### Ravaglioli Deutschland

Kirchenpoint 22  
85354 Freising  
Tel. 08165-646956  
Fax 08165-646958  
info@ravaglioli.de

#### RAV Equipment UK LTD

Prince Albert House  
20 King Street  
Maidenhead, SL6 1DT  
ravuk@ravaglioli.com

#### RAV en Belgique

Nederlandstalig  
Tel. 0498-162016  
Fax 016-781025  
Zone Francophone  
Tel. 0498-163016  
Fax 078 055030

#### RAV Equipos España

Avenida Europa 17  
Pol. Ind. de Constanti  
Tarragona 43120  
Tel. 977 524525  
Fax 977 524532  
ravequipos@ravaglioli.e.telefonica.net

DRT05U (1)

Le caratteristiche tecniche e gli allestimenti presentati in questo prospetto possono subire variazioni. Le immagini riprodotte non sono vincolanti.  
Technical data and composition presented in this catalogue may vary. Pictures reproduced are only indicative.  
Die techn. Daten und die Ausrüstungen, die in diesem Prospekt enthalten sind, können Änderungen erfahren. Deshalb sind die Abbildungen unverbindlich.  
Les caractéristiques techniques et les compositions présentées dans ce prospectus peuvent subir des variations. Les images reproduites n'ont qu'une valeur indicative.  
Las características técnicas y las composiciones ilustradas en este folleto pueden sufrir variaciones. Las imágenes propuestas son solamente indicativas.

